

PlugMiser™

PM150 / PM151 Installation Instructions

The PlugMiser™ is designed to operate as an intelligent power controller for any plug-in electrical loads, including a PC monitor, task lights, radio, and any other electrical office equipment, except for a computer itself. An optional power strip (USA #60022) is also available when more than one load is to be plugged into the PlugMiser.

To install the PlugMiser, follow these simple steps:

PlugMiser Power Controller

1. Unplug all the electrical equipment that you would like the PlugMiser to control (such as computer monitors, task lights, personal fans, radios, coffee warmers, space heaters, etc.). Caution-Do not exceed PlugMiser's load capacity (1230 Watts for 120VAC and 2000 Watts for 240 VAC). Note-Each load should remain on the same outlet/circuit breaker at the end of installation to ensure that the loads remain balanced and do not exceed any circuit limits.

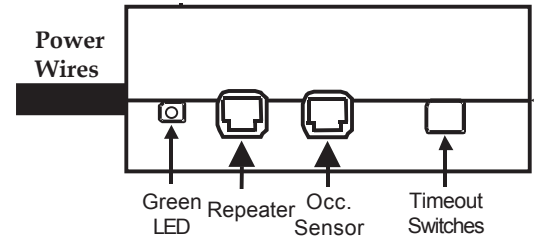

Power Connections

2. Plug all of the devices disconnected during Step 1 into the PlugMiser, or the optional power strip. Do not plug a computer into the PlugMiser's power strip. If used, ensure that the power switch on the power strip is "ON". Note that power will not appear at the power strip yet as the PlugMiser power cord has not been connected to the wall outlet.

Occupancy Sensor or Sensor Repeater Installation

3. The occupancy sensor has a telephone style connector at the end of its cable. After uncoiling the cable, plug this connector into the Occupancy Sensor connector on the PlugMiser (see diagram above). The connector labeled repeater is for use with multiple PlugMisers on a single sensor. Do NOT plug the sensor into anything other than the PlugMiser, or the sensor may be damaged.
4. The sensor must now be mounted in an appropriate location to ensure satisfactory operation. The infrared sensor must "See" thermal changes through the convex lens on the front of the unit. Note the sensor orientation in the picture on the right - ensure that the TOP of the sensor is facing the ceiling.

The following important criteria must be observed in selecting a sensor location:

- The sensor should be mounted so it will "See" the office occupant at the primary work stations – usually the computer and the telephone.
 - The sensor should not "See" the hallway or other high traffic areas (when mounted properly, the sensor does not "See" above the horizontal, but will see below itself very well)
 - The sensor should not point solely at the occupant's back, as thermal changes may be masked by hair and clothing
5. To mount the sensor, use the supplied plastic mounting bracket, shown on the right. This plastic bracket has predrilled holes and appropriate fasteners may be used to secure it to a surface or corner on which the sensor is to be attached. The sensor is then to be snapped into the bracket tabs which will hold the sensor in place. To remove the sensor at a later date, simply snap the sensor off the bracket by hand, pulling it straight out.

Sensor Mounting
Bracket

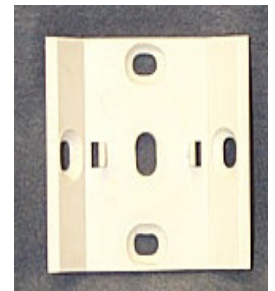

PIR Sensor



PlugMiser™

PM150 / PM151 Installation Instructions (cont'd.)

6. If a Secondary Miser is being installed, use the supplied 3 Meter (10 feet) phone style cable to connect the OCCUPANCY SENSOR connector on this Secondary to the REPEATER connector on the Primary SnackMiser. Additional Secondary PlugMisers can be daisy-chained using the same techniques shown in the diagram to the right. A maximum of four Misers can be daisy-chained in this fashion. It is acceptable to mix PlugMisers with SnackMisers, VendingMisers, and/or CoolerMisers provided the coverage of the sensor is acceptable for all devices sharing the sensor.

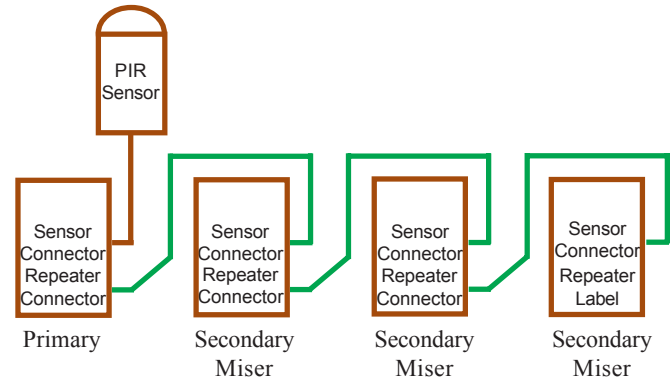

DIP Switch Settings

The DIP switches on the PlugMiser allow selection of a time-out period. The PlugMiser's time-out period is factory preset for 15 minutes. You may select any other time-out period that is appropriate for your environment as shown on the chart to the right (a copy of this chart is also located on the PlugMiser label). It is recommended that the factory preset 15 minute time-out be used initially. Note that all but two of the time-out selections which are signified by the "*" will automatically power off 30 seconds after the initial PlugMiser power on. This enables a quick test of the unit without having to wait an excessive amount of time or having to change DIP switches after installation. Once this initial power off has occurred, the PlugMiser will automatically resume the selected time-out period.

Switch Settings
↑↑↑ = 3 Seconds
↑↑↓ = 2 Hours
↑↓↑ = 3 Hours
↑↓↓ = 1 Hour
↓↑↑ = 25 Minutes*
↓↑↓ = 15 Minutes*
↓↓↑ = 25 Minutes
↓↓↓ = 15 Minutes

First Timeout after power up is 30 seconds except *

Power-Up Testing and Installation Validation

Connect the PlugMiser's power cord to a wall outlet or power strip.

Verify correct operation of the occupancy sensor by confirming that the Green light behind the sensor lens comes on after power up. The sensor must be allowed to warm up and stabilize for several minutes before its placement can be verified. During this warm-up period, the sensor may go dark – this is normal behavior. Once the sensor is warmed up, it will flash Green at the slightest movement within its field of view. Validate that the sensor can "See" the occupant in all areas of the office, and it does not see movement outside the office. If necessary, relocate the sensor and repeat the coverage test.

The Green light on the PlugMiser will flash twice at power up to indicate that the PlugMiser has passed its self checks. During normal operation the green light will be on continuously to indicate occupancy is detected or will flash on and off every few seconds to indicate no occupancy is detected. This allows validation that the sensor is correctly connected to the PlugMiser and is operating properly.

As noted above in the Switch Settings table, all but two of the time-out selections will power off in 30 seconds to enable complete testing of the installed PlugMiser. All subsequent time-outs will be according to the DIP switch selection.