

SnackMiser™

SM150 / SM151 Installation Instructions

SnackMiser™ is designed to operate as an intelligent power controller for non-refrigerated vending machines. Note that SnackMiser may not be used on any vending machine which contains refrigerated products.

General Theory of Operation

Using a Passive Infrared (PIR) occupancy sensor, SnackMiser will automatically shut down the controlled vending machine when the area around the machine has been vacant for 15 minutes (factory default) or whatever time the unit is set for by the Timeout Switches.

To install the SnackMiser, follow these simple steps:

Locating and Mounting the SnackMiser

1. Unplug the vending machine's power cord from the outlet. If it is necessary to move the machine, be careful as it can be heavy.
2. Identify a suitable mounting location for SnackMiser, most likely on the wall behind the vending machine. SnackMiser must be located so that the machine's power cord can reach the SnackMiser, and SnackMiser's power cord can reach the power outlet.
3. SnackMiser should be oriented so that the operational light is viewable by maintenance personnel.
4. Using screws appropriate for the wall material, attach SnackMiser's steel mounting bracket to the identified location with the UP arrow facing towards the ceiling. "Snap" the SnackMiser DOWNWARDS onto the mounting bracket (To remove SnackMiser later, "Snap" the unit UPWARDS.).
5. Plug the vending machine's power cord into the SnackMiser. Do not yet plug the SnackMiser into the wall outlet at this stage of the installation.

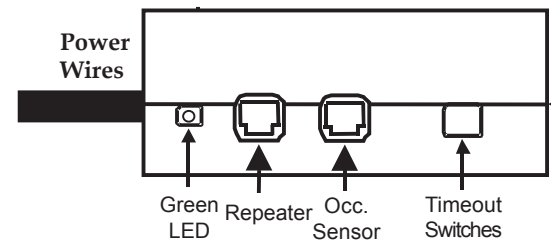

Occupancy Sensor or Sensor Repeater Installation

6. If this SnackMiser is stand-alone, or the first unit in a bank of machines, a PIR sensor must be installed, as described below, to create a Primary SnackMiser. If this SnackMiser is not the first unit in a bank, skip to Step 10 to install a Secondary SnackMiser.
7. The PIR sensor must be located so that it can "See" anyone approaching the vending machine. Ideally, the sensor should be mounted on the wall behind the vending machine, about two feet above the machine. Note the picture on reverse side of this document - ensure that the TOP of the sensor is facing the ceiling.

If low ceiling height above the vending machine does not allow wall mounting, mount on the ceiling in front of the vending machine. This requires that the "TOP" of the sensor points towards the vending machine to ensure proper operation. Always avoid sensor placement near air ducts which can falsely trigger the sensor.

SnackMiser™

SM150 / SM151 Installation Instructions (cont'd.)

- To mount the sensor, use the supplied plastic mounting bracket shown to the right. Use appropriate fasteners to secure it to the selected surface. Then snap the sensor over the bracket. To remove the sensor at a later date, snap the sensor off the bracket by pulling it straight out.
- The occupancy sensor has a telephone style connector at the end of its cable. Plug this connector into the center socket on the SnackMiser. It is recommended that the sensor cable be secured to the wall or ceiling by covering the cable with plastic low voltage wire raceway.
- If a Secondary SnackMiser is being installed, use the supplied 3 Meter (10 feet) phone style cable to connect the OCCUPANCY SENSOR connector on this Secondary to the REPEATER connector on the Primary SnackMiser. Additional Secondary SnackMiser's can be daisy-chained using the same techniques shown in the diagram to the right. A maximum of four Misers can be daisy-chained in this fashion. It is acceptable to mix SnackMisers with PlugMisers, VendingMisers, and/or CoolerMisers provided the coverage of the sensor is acceptable for all devices sharing the sensor.

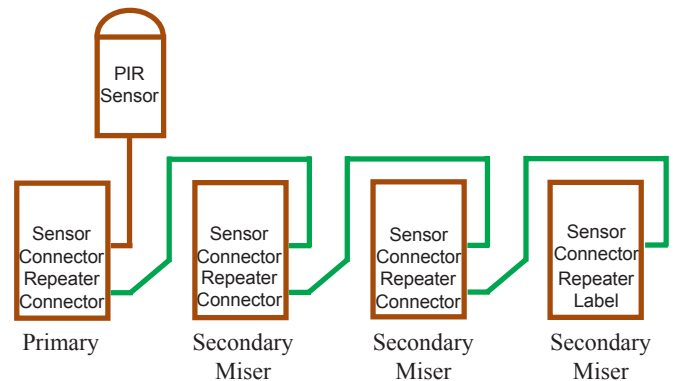
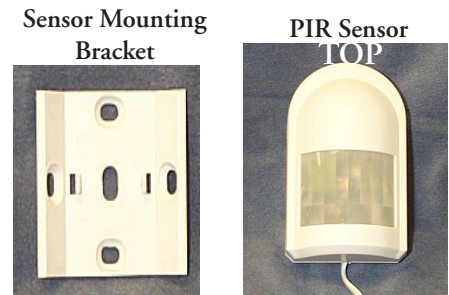

Power-Up Testing and Install Validation

Plug the SnackMiser into the wall outlet. The following should occur:

- The vending machine should power up immediately.
- The Green LED should flash twice to indicate that the SnackMiser is functional.
- The Green LED will be on solid to indicate occupancy is detected.
- The Green LED will indicate no occupancy by flashing off every few seconds.

| Switch Settings |
|-------------------|
| ↑↑↑ = 3 Seconds |
| ↑↑↓ = 2 Hours |
| ↑↓↑ = 3 Hours |
| ↑↓↓ = 1 Hour |
| ↓↑↑ = 25 Minutes* |
| ↓↑↓ = 15 Minutes* |
| ↓↓↑ = 25 Minutes |
| ↓↓↓ = 15 Minutes |

First Timeout after power up is 30 seconds except *

Verify correct operation of the occupancy sensor by confirming that the Green light behind the sensor lens comes on after power up. The sensor must be allowed to warm up and stabilize for several minutes before its placement can be verified. During this warm-up period, the sensor may go dark – this is normal behavior. Once the sensor is warmed up, it will flash Green at the slightest movement within its field of view. Validate that the sensor can "See" the occupant in all desired areas around the snack machine. If necessary, relocate the sensor and repeat the coverage test.

- As a final functional test, the SnackMiser will power-down the first time only after installation approximately thirty seconds after the area around the machine is vacant. Covering the occupancy sensor will allow validation of the power-down operation if so desired. Following this initial power-down, the SnackMiser will operate with its standard 15 minute time-out or as set by the timeout switches, and will immediately turn the power on when occupancy is detected.

As noted above in the Switch Settings table, all but two of the time-out selections will power off 30 seconds after initial power-up to enable complete testing of the installed SnackMiser. All subsequent time-outs will be according to the Timeout Switch selection.

